

# Cast Steel Check Valve



## Contents

**Model Code System Instructions(1)**

**Design Features&Specifications for API Cast Steel Swing Check Valve (2)**

**Bolted Bonnet Swing Check Valve(3-4)**

**Pressure Seal Swing Check Valve(5-6)**

**Flange Connection API Piston-Lift Type Swing Check Valve (7-9)**

**Wafer Type Double Disc Swing Check Valve(10-12)**

**Wafer Type Piston-Lift Check Valve(13-15)**

## Model Code System Instructions

□	□	□	□	□	□	□
Code of valve type	Code of pressure	Code of structure	Code of driving manner	Code of connect tube wall thickness	Code of connection end	Code of body material

- Valve type code: H- Check valve
- Pressure code: 2-CL150    3-CL300    5-CL600    7-CL900    8-CL1500    9-CL2500
- Structure code: 1-BC-Swing (bolted bonnet-swing type)
  - 1<sub>L</sub>-PS-Swing (pressure seal bonnet-swing type)
  - 2-BC-Piston-Lift(bolted bonnet-piston-lift type)
  - 3-Wafer-Swing(wafer-swing type)
  - 3<sub>L</sub>-Wafer-Piston-Lift(wafer-piston-lift type)

- Connecting pipe wall thickness:

Code	Wall Thickness	Code	Wall Thickness	Code	Wall Thickness
S1	SCH10	S4	SCH40	S7	SCH120
S2	SCH20	S5	SCH60	S8	SCH140
S3	SCH30	S6	SCH80	S9	SCH160

- Connection code: R-RF (raised face flange)    J-RJ (ring joint flange)  
F-FM (male-female face flange)    W-BW (butt weld)
- Special structure code:  
FS-bolted bonnet structure    PS-pressure seal structure
- Body material code:
  - 1) Cast carbon steel: CC10—ASTM A216 WCB
  - 2)Cast alloy steel: CA20—ASTM A217 WC1    CA21—ASTM A217 WC6    CA22—ASTM A217 WC9  
CA23—ASTM A217 C5    CA24—ASTM A217 C12
  - 3)Cast stainless steel: CS30—ASTM A351 CF8    CS31—ASTM A351 CF8M    CS32—ASTM A351 CF8C  
CS33—ASTM A351 CF3    CS34—ASTM A351 CF3M

## Flange&Butt Weld API Cast Steel Swing Check Valve

### Products Design Features

API cast steel swing check valves are usually applied to prevent backward influx of medium in pipeline systems of oil industry, chemical industry, pharmacy, fertiliser facilities, power plants etc. The applicable pressure range is CL150-2500 and working temperature is -29°C~600°C.

1. The design features rational structure, reliable sealing, excellent performance and better appearance;
2. Co hard alloy welded sealing surface is resistant in wearing, erosion and abrasion, hence has longer service life;
3. Inside-set bolt-bearing structure reduces leakage and increase reliability;
4. The central cavity with pressure  $\geq$ CL1500 adopts self-tightening seal structure in which sealing ability rises with internal pressure to ensure sealing reliability;
5. Spare parts material, flange, welding end sizes are optional per working conditions and customer's requirement ;

### Products Specifications

Model	Structure	Class	Nominal Size													
			2	2 <sup>1/2</sup>	3	4	5	6	8	10	12	14	16	18	20	24
H21RFS	Bolted bonnet, swing type	150	☆	☆	☆	☆	☆	☆	☆	☆	☆	☆	☆	☆	☆	-
H31RFS		300	☆	☆	☆	☆	☆	☆	☆	☆	☆	☆	☆	☆	☆	-
H51JFS		600	☆	☆	☆	☆	☆	☆	☆	☆	☆	☆	☆	☆	-	-
H51S7WPS	Pressure bonnet, swing type	600	☆	☆	☆	☆	☆	☆	☆	☆	☆	☆	☆	☆	☆	☆
H71S7WPS		900	☆	☆	☆	☆	☆	☆	☆	☆	☆	☆	☆	☆	☆	
H81S9WPS		1500	☆	☆	☆	☆	☆	☆	☆	☆	☆	☆	☆	☆	☆	
H91SPWPS		2500	☆	☆	☆	☆	☆	☆	☆	☆	☆	-	-	-	-	-

### Products Performance Specifications

Nominal pressure	Class					
	150	300	600	900	1500	2500
Shell test(Mpa)	3.0	7.8	15.0	20.1	37.5	63.0
Seal test(Mpa)	2.2	5.7	11.0	14.7	27.5	46.2
Temperature	$\leq 570^{\circ}\text{C}$					
Medium	Water, oil, gas					

## Bolted Bonnet Swing Check Valve



Technical Specification	
Structure	BC-Swing
Design standard	API 6D
Face to face	ASME B16.10
Flange connection	ASME B16.5
Test&inspection	API 598

Note: The flange size can be designed per customer requirement.

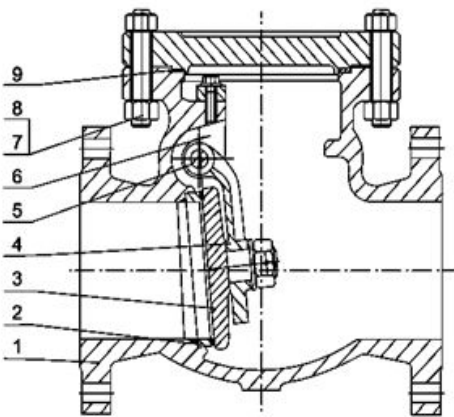

Major Parts Material		
No.	Name	Material
1	Body	ASTM A216 WCB ASTM A217 WC1,WC6,WC9,C5 ASTM A351 CF8,CF8M,CF8C,CF3,CF3M
2	Seat	ASTM A105 ASTM A182 F11,F22,F5,F9 ASTM A182 F304,F316,F321,F304L,F316L
3	Disc	ASTM A216 WCB ASTM A217 WC1,WC6,WC9,C5 ASTM A351 CF8,CF8M,CF8C,CF3,CF3M
4	Arm	ASTM A216 WCB ASTM A217 WC1,WC6,WC9,C5 ASTM A351 CF8,CF8M,CF8C,CF3,CF3M
5	Pin	ASTM A182 Gr.F6a F22 ASTM A182 F304,F316,F321,F304L,F316L
6	Connector	ASTM A216 WCB ASTM A217 WC1,WC6,WC9,C5 ASTM A351 CF8,CF8M,CF8C,CF3,CF3M
7	Stud	ASTM A193 B7,A320 B8 ,A193 B8M
8	Hex nut	ASTM A194 2H,A194 8,A194 8M
9	Gasket	graphite+stainless steel

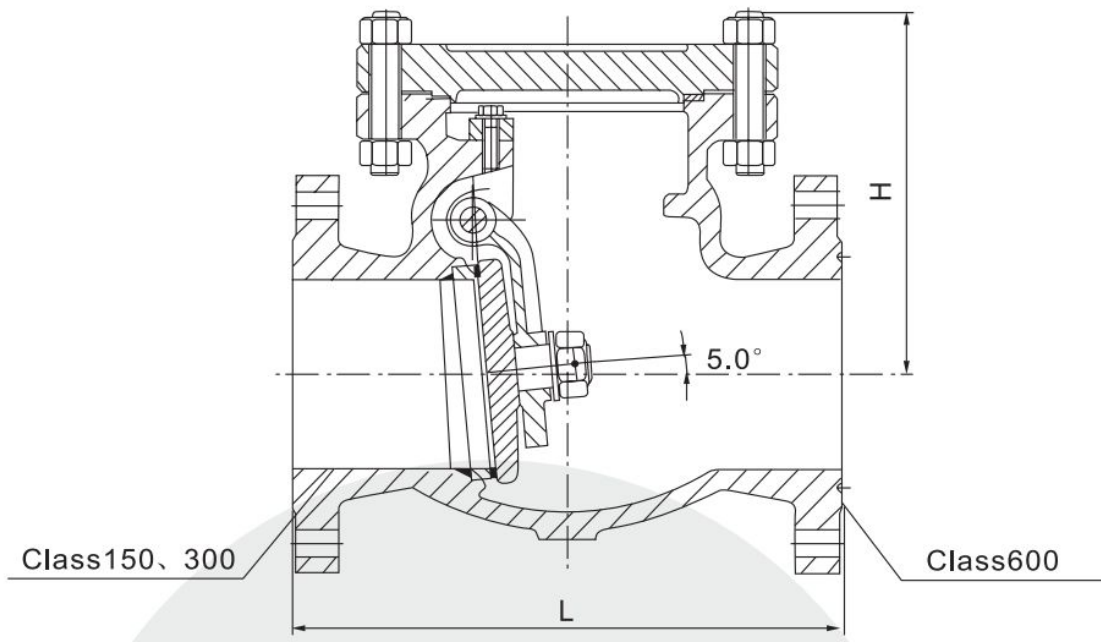

<b>Size&amp;Weight</b>										
Model		H21RFS—CC10,CA20,CS30			H31RFS—CC10,CA20,CS30			H51JFS—CC10,CA20,CS30		
	CL150			CL300			CL600			
Size	L	H	Weight(Kg)	L	H	Weight(Kg)	L	H	Weight(Kg)	
2	203	165	17	267	175	22	295	200	32	
2 1/2	216	182	26	292	186	24	334	219	42	
3	241	195	32	318	212	38	359	232	61	
4	292	208	45	356	238	52	435	282	112	
6	356	260	75	444	302	86	562	330	205	
8	495	295	135	533	362	165	664	378	385	
10	622	350	200	622	392	204	791	452	575	
12	699	405	275	711	440	278	842	575	775	
14	787	446	385	838	460	402	892	590	982	
16	864	493	442	864	530	545	991	635	1056	
18	978	515	630	978	582	683	—	—	—	
20	978	540	760	1016	615	862	—	—	—	

## Pressure Seal Swing Check Valve



### Technical Specification

Structure	PC-Swing
Design standard	API 6D
Face to face	ASME B16.10
Flange connection	ASME B16.5
Butt weld	ASME B16.25
Test&inspection	API 598

Note: The flange size can be designed per customer requirement.

### Major Parts Material

No.	Name	Material
1	Body	ASTM A216 WCB ASTM A217 WC1,WC6,WC9,C5 ASTM A351 CF8,CF8M,CF8C,CF3,CF3M
2	Disc	ASTM A216 WCB ASTM A217 WC1,WC6,WC9,C5 ASTM A351 CF8,CF8M,CF8C,CF3,CF3M
3	Seat	ASTM A105 ASTM A182 F11,F22,F5,F9 ASTM A182 F304,F316,F321,F304L,F316L
4	Pin	ASTM A182 Gr.F6a F22 ASTM A182 F304,F316,F321,F304L,F316L
5	Arm	ASTM A216 WCB ASTM A217 WC1,WC6,WC9,C5 ASTM A351 CF8,CF8M,CF8C,CF3,CF3M
6	Bonnet	ASTM A105 ASTM A182 F11,F22,F5,F9 ASTM A182 F304,F316,F321,F304L,F316L
7	Seal ring	Flexible graphite
8	Gland	ASTM A216 WCB ASTM A217 WC1,WC6,WC9,C5 ASTM A351 CF8,CF8M,CF8C,CF3,CF3M
9	Stud	ASTM A193 B7,A320 B8 ,A193 B8M
10	Hex nut	ASTM A194 2H,A194 8,A194 8M

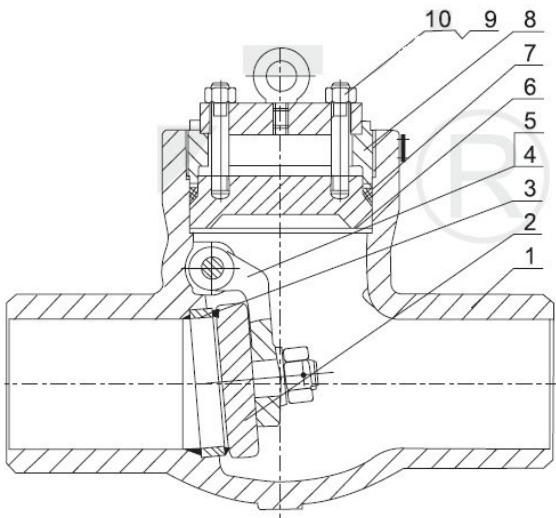

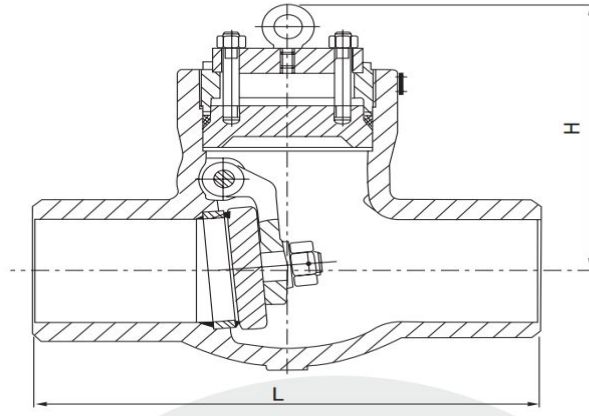

Size&Weight													CL600	
Model													H51S7WPS-CC10,CA20,CS30	
Size	2	2 <sup>1</sup> / <sub>2</sub>	3	4	6	8	10	12	14	16	18	20	24	
L(mm)	292	330	356	432	559	660	787	838	889	991	1092	1194	1397	
H(mm)	225	240	254	279	368	393	457	584	609	685	736	762	889	
Weight(Kg)	29	35	48	67	440	205	325	480	600	800	1490	1675	2300	
Connecting pipe wall thickness(mm): SCH 120														
Size&Weight													CL900	
Model													H71S7WPS-CC10,CA20,CS30	
Size	2	2 <sup>1</sup> / <sub>2</sub>	3	4	6	8	10	12	14	16	18	20	24	
L(mm)	368	419	381	457	610	737	838	965	1029	1130	1219	1549	1549	
H(mm)	225	240	254	279	381	533	558	609	736	762	863	939	1066	
Weight(Kg)	48	65	70	100	245	425	675	900	1125	1600	2000	2700	3500	
Connecting pipe wall thickness(mm): SCH 120														
Size&Weight													CL1500	
Model													H71S7WPS-CC10,CA20,CS30	
Size	2	2 <sup>1</sup> / <sub>2</sub>	3	4	6	8	10	12	14	16	18	20	24	
L(mm)	368	419	470	546	705	832	991	1130	1257	1384	1537	1664	1943	
H(mm)	225	240	254	279	405	567	585	630	750	787	885	960	1120	
Weight(Kg)	48	65	90	115	250	470	800	1350	1800	2200	2600	2700	4100	
Connecting pipe wall thickness(mm): SCH 160														
Size&Weight													CL2500	
Model													H71S7WPS-CC10,CA20,CS30	
Size	2	2 <sup>1</sup> / <sub>2</sub>	3	4	6	8	10	12						
L(mm)	451	508	578	673	914	1022	1270	1422						
H(mm)	225	249	254	279	420	570	1010	1160						
Weight(Kg)	80	102	120	220	540	920	1692	2296						
Connecting pipe wall thickness(mm): SCH 160														

Note: The piping size can be designed per customer requirement.



## Flange Connection API Piston-Lift Type Swing Check Valve

### Products Design Features

Flanged ends piston-lift type check valve are used in pipes under nominal pressure under CL150~900, working temperature between -29~550°C. They are applied to oil, chemistry, pharmacy, fertilizing, power industries to avoid backward influx of the medium inside the pipeline.

1. The design features rational structure, reliable sealing, excellent performance and better appearance;
2. Co hard alloy welded sealing surface is resistant in wearing, erosion and abrasion, hence has longer service life;
3. Spare parts material, flange, welding end sizes are optional per working conditions and customer's requirement ;

### Products Specifications

Model	Structure	Classes	Nominal size									
			2	2 <sup>1/2</sup>	3	4	5	6	8	10	12	
H22RFS	Bolted bonnet, piston-lift type	150	☆	☆	☆	☆	☆	☆	☆	☆	☆	☆
H32RFS		300	☆	☆	☆	☆	☆	☆	☆	☆	☆	☆
H52JFS		600	☆	☆	☆	☆	☆	☆	☆	☆	☆	☆
H72JFS		900	☆	☆	☆	☆	☆	—	—	—	—	—

### Products Performance Specifications

Nominal pressure	Class			
	150	300	600	900
Shell test (Mpa)	3.0	7.8	15.0	20.1
Seal test (Mpa)	2.2	5.7	11.0	14.7
Temperature:	≤550°C			
Medium	Water, oil, gas			



Technical Specification	
Structure	BC-PISTON-LIFT
Design standard	BS 1868
Face to face	ASME B16.10
Flange connection	ASME B16.5
Test&inspection	API 598

Note:The flange size can be designed per customer requirement.

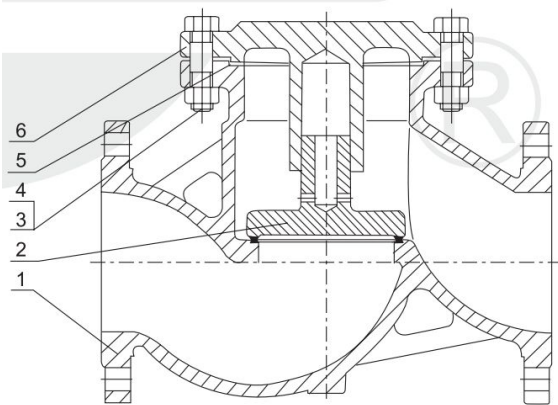

Major Parts Material		
No.	Name	Material
1	Body	ASTM A216 WCB ASTM A217 WC1,WC6,WC9,C5 ASTM A351 CF8,CF8M,CF8C,CF3,CF3M
2	Disc	ASTM A216 WCB ASTM A217 WC1,WC6,WC9,C5 ASTM A351 CF8,CF8M,CF8C,CF3,CF3M
3	Stud	ASTM A193 B7,A320 B8 ,A193 B8M
4	Hex nut	ASTM A194 2H,A194 8,A194 8M
5	Gasket	Graphite+stainless steel
6	Bonnet	ASTM A216 WCB ASTM A217 WC1,WC6,WC9,C5 ASTM A351 CF8,CF8M,CF8C,CF3,CF3M

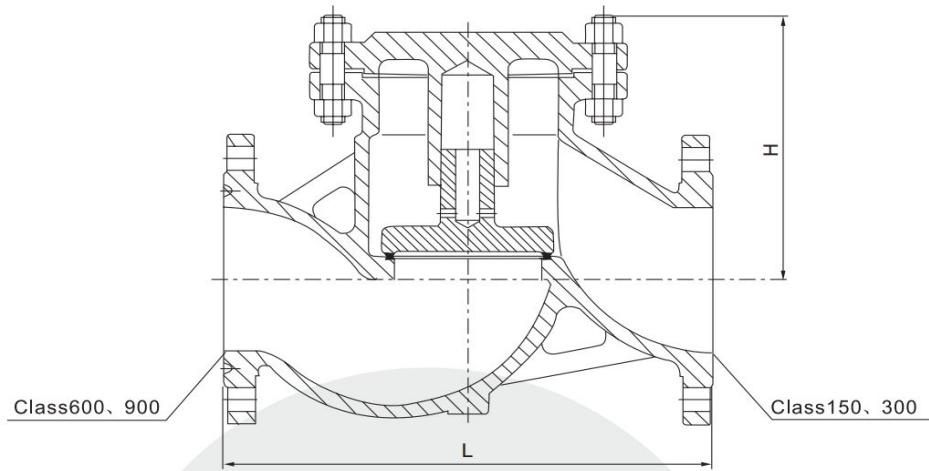

Size&Weight								CL150
Model								H22RFS-CC10,CA20,CS30
Size	2	2½	3	4	6	8	10	12
L(mm)	203	216	241	292	356	459	622	698
H(mm)	165	175	190	215	265	320	365	415
Weight(Kg)	17	25	29	50	85	150	240	350
Size&Weight								CL300
Model								H32RFS-CC10,CA20,CS30
Size	2	2½	3	4	6	8	10	12
L(mm)	267	292	318	356	444	533	622	711
H(mm)	190	205	220	245	295	330	420	480
Weight(Kg)	28	33	45	70	150	230	390	520
Size&Weight								CL600
Model								H52JFS-CC10,CA20,CS30
Size	2	2½	3	4	6	8	10	12
L(mm)	295	334	359	435	562	664	791	842
H(mm)	210	230	255	295	365	420	505	545
Weight(Kg)	33	43	62	113	222	390	630	871
Size&Weight								CL900
Model								H71S7WPS-CC10,CA20,CS30
Size	2	2½	3	4	6			
L(mm)	372	422	384	460	613			
H(mm)	235	270	302	342	425			
Weight(Kg)	120	166	176	182	403			

## Wafer Type Double Disc Swing Check Valve

### Products Design Features

Wafer type double disc swing check valves are used in all kinds of pipes under pressure CL150~900, working temperature of -196~425°C. They are mainly used to prevent the reverse influx of medium inside the pipes.

1. Short length, small size and light weight;
2. Either soft sealing or hard sealing can be applied for the sealing surface according to different working conditions, both of which can achieve a excellent sealing effect.
3. With a small starting pressure, the valve discs can be fully opened under a very small pressure difference.
4. Fast discs closing and small water hammer pressure;
5. Convenient installation in both level and vertical pipe direction;
6. Different materials for the parts, sizes and forms of the valves surfaces are available for free combination according to the working conditions and customer requirements.

### Products Specification

Model	Class	Nominal size													
		2	2 <sup>1/2</sup>	3	4	5	6	8	10	12	14	16	18	20	24
H23R	150	☆	☆	☆	☆	☆	☆	☆	☆	☆	☆	☆	☆	☆	☆
H33R	300	☆	☆	☆	☆	☆	☆	☆	☆	☆	☆	☆	—	—	—
H53J	600	☆	☆	☆	☆	☆	☆	☆	☆	☆	—	—	—	—	—
H73J	900	☆	☆	☆	☆	☆	☆	☆	—	—	—	—	—	—	—

### Products Performance Specification

Nominal pressure	Class			
	150	300	600	900
Shell test (Mpa)	3.0	7.8	15.0	20.1
Seal test (Mpa)	2.2	5.7	11.0	14.7
Temperature	≤550°C			
Medium	Water, oil, gas			



Technical Specification	
Structure	WAFER-TYPE
Design standard	API 594
Face to face	ASME B16.10
Flange connection	ASME B16.5
Test&inspection	API 598

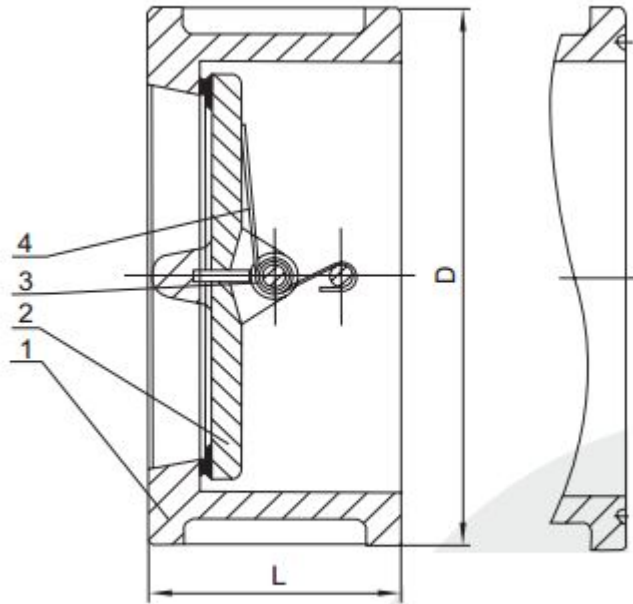

CL150,300

CL600,900

Major Parts Materials		
No.	Name	Material
1	Body	ASTM A216 WCB ASTM A351 CF8,CF8M,CF8C,CF3,CF3M
2	Disc	ASTM A216 WCB ASTM A351 CF8,CF8M,CF8C,CF3,CF3M
3	Pin	ASTM A182 Gr.F6a,F22 ASTM A182 F304,F316,F321,F304L,F316L
4	Spring	AISI 9260,AISI 6150 ASTM A182 F304,F316,F321,F304L,F316L

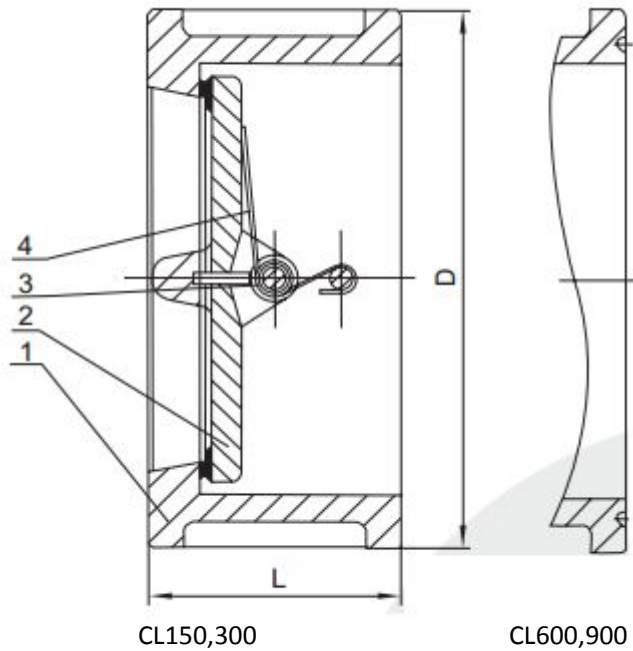

Size&Weight													CL150	
Model													H23R-CC10,CS30	
Size	2	2½	3	4	5	6	8	10	12	14	16	18	20	24
L(mm)	60	67	73	73	86	98	127	146	181	184	191	203	219	222
H(mm)	103	122	135	173	196	222	279	339	409	450	514	549	606	717
Weight (Kg)	2	3.2	4	6	9	12	22	38	54	80	118	210	240	410
Size&Weight													CL300	
Model													H33R-CC10,CS30	
Size	2	2½	3	4	5	6	8	10	12	14	16			
L(mm)	60	67	73	73	86	98	127	146	181	222	232			
H(mm)	110	129	148	180	215	250	307	361	422	485	539			
Weight (Kg)	3.5	5	7	10	18.5	19	33	54	88	128	169			
Size&Weight													CL600	
Model													H53J—CC10,CS30	
Size	2	2½	3	4	5	6	8	10	12	14	16			
L(mm)	60	67	73	79	105	136	165	213	229	273	305			
H(mm)	110	129	148	192	240	265	319	399	456	489	562			
Weight (Kg)	3.5	5	7	12	22.5	35	45	77	110	135	163			
Size&Weight													CL900	
Model													H73J—CC10,CS30	
Size	2	2½	3	4	6	8								
L(mm)	70	83	83	102	159	206								
H(mm)	142	164	167	205	288	358								
Weight (Kg)	6.5	9	14	24	43	56								

## Wafer Type Piston-Lift Check Valve

### Products Design Features

Wafer & Piston-Lift Check Valves are used in all kinds of pipes under the pressure of CL150~900 and working temperature of -196~425°C. They are mainly used to avoid the reverse flux of the medium. The main structure features:

1. Short length, small volume and light weight;
2. Hard material welded sealing surface, which is wearing resistant, erosion proof abrasion proof and longer use life;
3. With a small starting pressure, the valve discs can be fully opened under a very small pressure difference;
4. Fast discs closing and small water hammer pressure;
5. Easy installation in both level and vertical pipeline;
6. Different materials for the parts, sizes and forms of the valves surfaces are available for free combination according to the working facts and the customer's requirements.

### Products Specification

Model	Structure	Class	Nominal size										
			1/2	3/4	1	1 1/4	2	2 1/2	3	4	5	6	
H23R	Wafer, piston-lift type	150	☆	☆	☆	☆	☆	☆	☆	☆	☆	☆	☆
H33R		300	☆	☆	☆	☆	☆	☆	☆	☆	☆	☆	☆
H53J		600	☆	☆	☆	☆	☆	☆	☆	☆	☆	☆	☆
H73J		900	☆	☆	☆	☆	☆	☆	☆	☆	☆	☆	☆

### Products Performance Specifications

Nominal pressure	Class			
	150	300	600	900
Shell test (Mpa)	3.0	7.8	15.0	20.1
Seal test (Mpa)	2.2	5.7	11.0	14.7
Temperature	≤425°C (different materials for different working temperature)			
Medium	Water, oil, gas and other corrosive medium			



**Technical Specifications**

Structure	WAFER-TYPE
Design standard	API 594
Face to face	ASME B16.10
Flange connection	ASME B16.5
Test&inspection	API 598

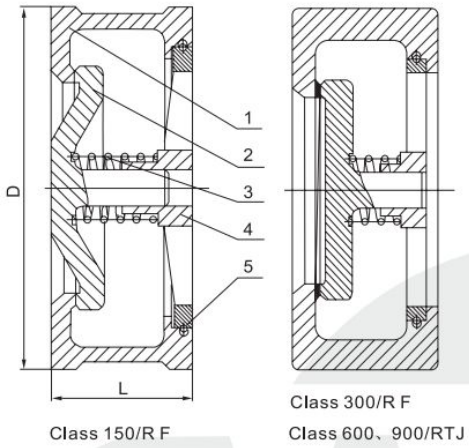

No.	Name	Material
1	Body	ASTM A216 WCB ASTM A351 CF8,CF8M,CF8C,CF3,CF3M
2	Disc	ASTM A216 WCB ASTM A351 CF8,CF8M,CF8C,CF3,CF3M
3	Spring	AISI 9260,AISI 6150 ASTM A182 F304,F316,F321,F304L,F316L
4	Pressing plate	ASTM A216 WCB ASTM A351 CF8,CF8M,CF8C,CF3,CF3M
5	Retainer ring	AISI 9260,AISI 6150 ASTM A182 F304,F316,F321,F304L,F316L



Size&Weight											CL150
Model											H23R-CC10,CS30
Size	1/2	3/4	1	1 <sup>1</sup> / <sub>4</sub>	1 <sup>1</sup> / <sub>2</sub>	2	2 <sup>1</sup> / <sub>2</sub>	3	4	5	6
L (mm)	16	19	22	28	31.5	40	46	50	60	90	106
H (mm)	47	57	66	75	85	103	122	135	173	196	222
Weight(Kg)	0.2	0.3	0.45	0.6	0.8	1.2	2.3	3.0	7.0	12	13
Size&Weight											CL300
Model											H33R-CC10,CS30
Size	1/2	3/4	1	1 <sup>1</sup> / <sub>4</sub>	1 <sup>1</sup> / <sub>2</sub>	2	2 <sup>1</sup> / <sub>2</sub>	3	4	5	6
L (mm)	25	31.5	35.5	40	45	56	63	71	80	110	125
H (mm)	53	65	72	81	95	110	129	148	180	215	250
Weight(Kg)	0.23	0.36	0.52	0.75	1.1	1.95	2.9	5.5	9.0	15	20
Size&Weight											CL600
Model											H23R-CC10,CS30
Size	1/2	3/4	1	1 <sup>1</sup> / <sub>4</sub>	1 <sup>1</sup> / <sub>2</sub>	2	2 <sup>1</sup> / <sub>2</sub>	3	4	5	6
L (mm)	25	31.5	35.5	40	45	56	63	71	80	110	125
H (mm)	53	65	72	81	95	110	129	148	192	240	265
Weight(Kg)	0.25	0.38	0.55	0.8	1.2	2.0	2.0	6.0	10	17	22
Size&Weight											CL900
Model											H33R-CC10,CS30
Size	1/2	3/4	1	1 <sup>1</sup> / <sub>4</sub>	1 <sup>1</sup> / <sub>2</sub>	2	2 <sup>1</sup> / <sub>2</sub>	3	4	5	6
L (mm)	25	31.5	35.5	40	45	56	63	71	80	110	125
H (mm)	63	69	78	88	98	142	164	167	205	247	288
Weight(Kg)	0.3	0.4	0.6	1.0	1.5	2.5	4.0	8.0	13	20	23